



Multi-Sense Sensor

Wireless Sensor Network Based on LoRa Technology

R31509

Data Sheet

Copyright©Netvox Technology Co., Ltd.

This document contains proprietary technical information which is the property of NETVOX Technology. It shall be maintained in strict confidence and shall not be disclosed to other parties, in whole or in part, without written permission of NETVOX Technology. The specifications are subject to change without prior notice.

Introduction

R31509 is a comprehensive detection device with door magnetism, light, temperature and humidity, water leak detection, and dry contact input.

The radio transmission of R31509 is based on LoRa long-distance technology. According to the required behavior and state, it can transmit information and data to the server, and can directly transmit and connect to the central system of the programmable alarm system.

The sensors used are reliable, accurate, and can detect multiple applications. R31509 has the advantages of durability, beautiful appearance, multi-function integration, low power consumption, and convenient installation and use.

Main Characteristic

- Adopt SX1262 wireless communication module
- 2 x 3.0V CR2450 button batteries in parallel
- Compatible with LoRaWAN™ Class A
- Frequency hopping spread spectrum (FHSS)
- Applicable to the third-party platforms: Actility/ThingPark, TTN, MyDevices/Cayenne
- Low power consumption and long battery life
- Battery life is determined by the sensor reporting frequency and other variables, please refer to http://www.netvox.com.tw/electric/electric_calc.html on this website, users can find the battery life of various models in different configurations.

Application

- Security system
- Villas
- Office
- Hotels and apartments
- Schools, shopping malls and supermarkets
- Others

Dimension

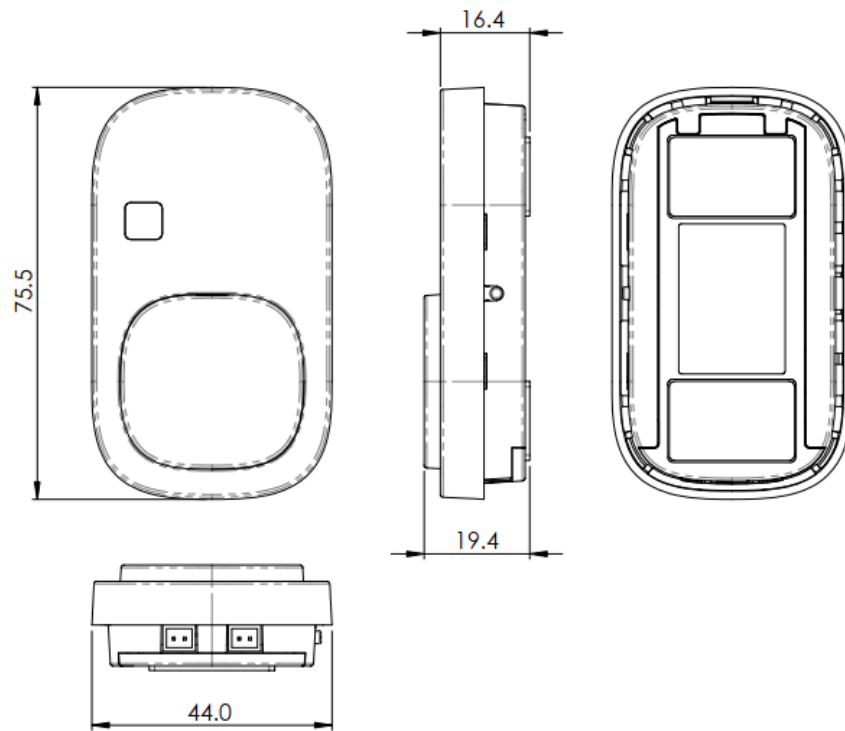

Main body- Include light sensor
(75.5mm x 19.4mm x 44mm)

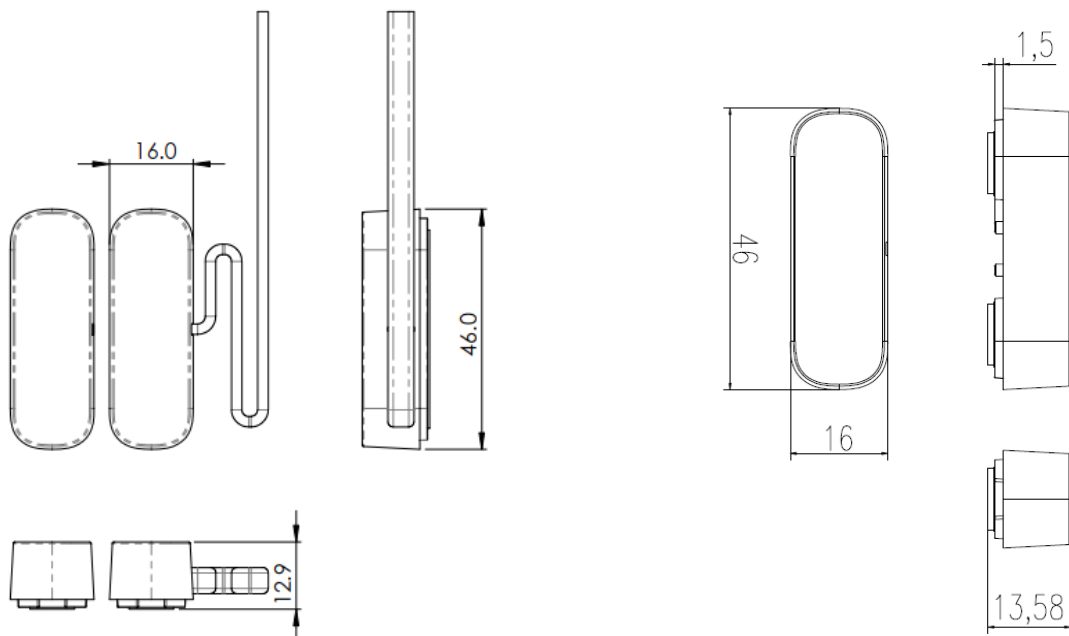

Reed Switch
(46mm x 16mm x 12.9mm)

Water Leak Sensor
(46mm x 16mm x 13.58mm)

The Port Types

The type of R31509 must be configured according to the rules.



Left	Center	Right
Water leak sensor	Dry contact input	Reed switch

Electrical Characteristics

---Electric---

Power Supply	2* 3V CR2450 button batteries connected in parallel (The capacity of a single CR2450 battery is 620mah, subject to the actual shipment)
Operating Voltage Range	2.3V to 3V
Battery Low Voltage Alarm	2.4V
Sleep Current	21uA/3.0V
Battery Measurement Accuracy	± 0.1V

*The specific electrical characteristics will vary depending on the supply voltage

---Light Sensor---

Illumination Measurement Range	1 Lux to 3000 Lux
Illumination Measurement Accuracy	<15%

---Reed Switch---

Minimum Insulation Resistance	$10^{10} \Omega$
Maximum Contact Resistance	100m Ω
Maximum Switching Current	0.5A

---Temperature and Humidity Sensor---

Temperature Measurement Range	-20°C to 55°C
Temperature Measurement Accuracy	$\pm 1^\circ\text{C}$
Humidity Measurement Range	0% RH to 100% RH
Humidity Measurement Accuracy	$\pm 7\%RH$

---Water Leak Sensor---

Rivet Material	Phosphor bronze
Rivet Surface Treatment	Nickel plated

---Frequency---

Frequency Range	863MHz-928MHz 470MHz-510MHz
TX Power	US915 20dbm; AS923 16dbm; AU915 20dbm; CN470 19.15dbm; EU868 16dbm; KR920 14dbm; IN865 20dbm;
Receiving Sensitivity	-123 dBm (Frequency deviation=5kHz, Bit Rate=1.2kb/s)
Antenna Type	Spiral antenna
Communication Distance	10 km(Visible linear obstacle-free transmission distance, actual transmission distance depending on the environment.)
Data Transfer Rate	0.6kbps ~ 300kbps
Modulation	FSK

Supportable LoRaWAN Frequency	EU863-870, US902-928, AU915-928, KR920-923, AS923-1, AS923-2, AS923-3, IN865, CN470-510 (Note: The frequency band is optional and needs to be configured before shipment.)
-------------------------------	---

---Physical---

Operating Temperature Range of R315 Host Body	-20°C to 55 °C
Environment Humidity Range	<90 %RH (No condensation)
Storage Temperature	-40°C to 85 °C

More Combinations

Please refer to this file:

http://www.netvox.com.tw/download/R315_combination.xlsx