

--- Wireless Temperature and humidity Sensor with Reed Switch and Glass Break Detector ---



S31501

Product Data Sheet

Copyright©Netvox Technology Co., Ltd.

This document contains proprietary technical information which is the property of NETVOX Technology. It shall be maintained in strict confidence and shall not be disclosed to other parties, in whole or in part, without written permission of NETVOX Technology. The specifications are subject to change without prior notice.

Introduction

S31501 is a comprehensive detection device with the functions of temperature and humidity detection, door magnetic switch and glass break detection. The S31501 device is suitable for data collection, and other applications such as home intelligent terminals and industrial applications.

S31501 has the advantages of durability, beautiful appearance, multi-functional integration, low power consumption, and convenient installation and use.

The S31501 device integrates the Amazon Sidewalk wireless module KG100S to enable its low power long-range connectivity to the Amazon Sidewalk network over 2.4GHz Bluetooth® Low Energy and Sub-GHz LoRa/FSK radio technologies. Customers can keep their S31501 device to stay connected to the Amazon Sidewalk network at no additional cost.

The microcontroller unit of the integrated wireless module also implements the Secure Vault™ technology to enable the highest level of IoT security. Together with multi layers of data encryption by the Amazon Sidewalk communication protocol, this converged solution has brought the S31501 device to the next level of enabling a versatile sensing solution for person/family security and asset protection while highly securing customer data to protect their privacy.

Main Characteristic

- 2 * 3.0V button batteries CR2450 supply power in parallel
- Sidewalk enabled connectivity over 2.4GHz BLE and Sub-GHz LoRa/FSK radio technologies. Amazon Sidewalk creates shared wireless networks connecting IoT devices at home and beyond the front door, across the entire neighborhood, and even the city.
- Low power consumption to extend long battery life.

Application

- Security system
- Villa
- Office
- Hotels and Apartments
- School, shopping mall, and supermarket
- Others

Dimension

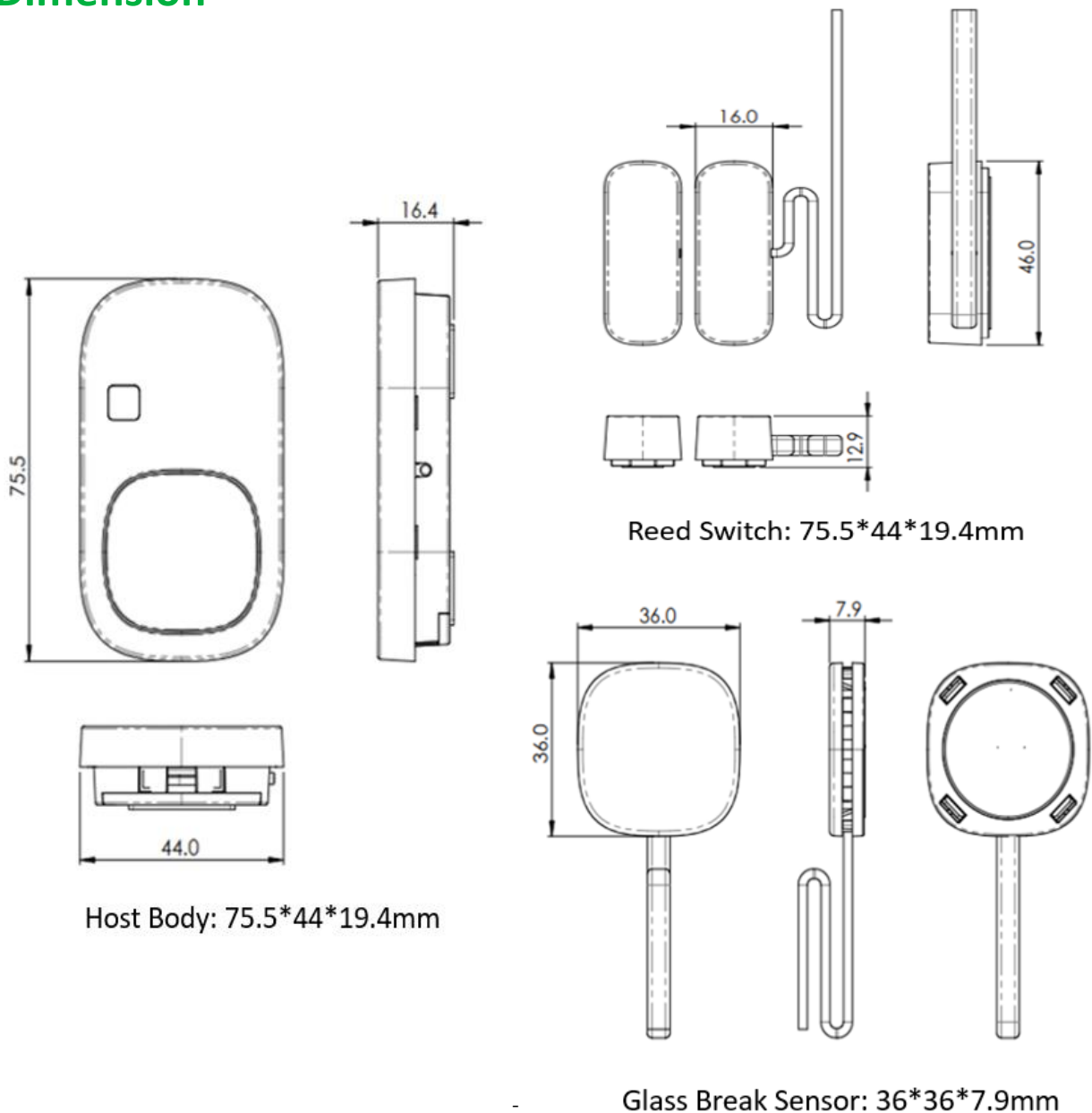

Electric

Power Supply	2 * 3V CR2450 button batteries in parallel
Operating Voltage Range	2.3 V ~ 3V
Battery Low Voltage Alarm	2.4 V
Battery Measurement Accuracy	±0.1 V

--- KG100S Wireless Module for Amazon Sidewalk ---

Power Supply Voltage	VSYS: 3 - 3.7V , typical value 3.3 V VMCU: 1.71 - 3.8V, typical value 1.8 V
Current	VSYS: 0.3 A (MAX) VMCU: 0.2 A (MAX)
Package Size	15 * 15 * 2.25mm, LGA-49 package

*The specific electrical characteristics will vary according to the power supply voltage

--- Temperature and Humidity Sensor ---

Temperature Range	-20°C ~ 55°C
Temperature Accuracy	TBD
Humidity Range	0%RH ~ 100%RH
Humidity Accuracy	TBD

--- Glass Break Sensor ---

Detection Mode	Piezoelectric buzzer
Power Supply	Self-generated voltage chip
Impedance	Normal (NC): 7Ω (max) Alarm (NO): 1MΩ (min)
Sensor Sensing Range	within 2.5 M radius
Signal Sensing Time	1 - 3 seconds
Loop Voltage	15 VDC (max)

Loop Current	25mA (max)
Applicable Glass Type	In theory, as long as any glass is impacted by high frequency, its vibration frequency and amplitude can be detected to a certain extent
Operating Temperature	-10 ~ 50 °C
Wire Length	100cm
Installation	The glass at the installation position must be wiped clean first, and then the double-sided adhesive tape on the back of the detector must be torn and fixed on the glass. The detector should be installed about 10 cm from the corner of the glass frame.

--- Reed Switch ---

Minimum Insulation Resistance	$10^{10} \Omega$
Maximum Contact Resistance	100m Ω
Maximum Switching Current	0.5A

Frequency

Frequency Range	863 MHz – 928 MHz
TX Power	20 dbm (under 3V power supply of button battery)
Receiving Sensitivity	-128 dBm (@BW 500KHz, SF11)
Antenna Type	Helical antenna (tentative)
Communication Distance	10 km (Theoretical value, visible linear obstacle-free transmission distance, actual transmission distance depending on the environment.)
Modulation	LoRa / FSK (Note: choose one of them)

Physical

Operating Temperature	-20°C ~ 55 °C
Storage Temperature	-40°C ~ 85 °C
Host Body Dimension	75.5mm * 44mm * 19.4mm
Reed Switch Dimension	46mm * 16mm * 12.9mm
Glass break Sensor Dimension	36mm * 36mm ** 7.9mm
Wire Length	100cm