

---

**Wireless Door/Window Sensor**

---

# **Wireless Door/Window Sensor**

## **R311A**

# **User Manual**

**Copyright©Netvox Technology Co., Ltd.**

This document contains proprietary technical information which is the property of NETVOX Technology. It shall be maintained in strict confidence and shall not be disclosed to other parties, in whole or in part, without written permission of NETVOX Technology. The specifications are subject to change without prior notice.

# Table of Content

1. Introduction.....	2
2. Appearance.....	3
3. Main Features .....	3
4. Set up Instruction.....	4
5. Data Report.....	5
5.1 Example of ReportDataCmd .....	5
5.2 Example of ConfigureCmd.....	6
5.3 Example for MinTime/MaxTime logic.....	7
6. Installation .....	8
7. Important Maintenance Instruction .....	10

## 1. Introduction

R311A is a long-distance window/door sensor based on the LoRaWAN open protocol (Class A).

### **LoRa Wireless Technology:**

LoRa is a wireless communication technology famous for its long-distance transmission and low power consumption. Compared with other communication methods, LoRa spread spectrum modulation technique greatly extend the communication distance. It can be widely used in any use case that requires long-distance and low-data wireless communications. For example, automatic meter reading, building automation equipment, wireless security systems, industrial monitoring. It has features like small size, low power consumption, long transmission distance, strong anti-interference ability and so on.

### **LoRaWAN:**

LoRaWAN uses LoRa technology to define end-to-end standard specifications to ensure interoperability between devices and gateways from different manufacturers.

This device has been certified by the LoRa Alliance and is allowed to use the following logo on the product:



## 2. Appearance



## 3. Main Features

- Compatible with LoRaWAN
- 2 sections of 3V CR2450 button battery power supply
- Reed switch status detection
- Simple operation and setting
- Protection level IP30
- Compatible with LoRaWAN™ Class A
- Frequency hopping spread spectrum technology
- Configuration parameters can be configured through third-party software platforms, data can be read and alarms can be set via SMS text and email (optional)
- Available third-party platform: Actility / ThingPark, TTN, MyDevices/Cayenne
- Low power consumption and long battery life

Note:

Battery life is determined by the sensor reporting frequency and other variables, please refer to

[http://www.netvox.com.tw/electric/electric\\_calc.html](http://www.netvox.com.tw/electric/electric_calc.html) On this website, users can find battery life time for varied models at different configurations.

## 4. Set up Instruction

### On/Off

Power on	Insert batteries. (users may need a flat blade screwdriver to open); Insert two sections of 3V CR2450 button batteries and close the battery cover.)
Turn on	Press any function key till green and red indicator flashes once.
Turn off (Restore to factory setting)	Press and hold the function key for 5 seconds till green indicator flashes for 20 times.
Power off	Remove Batteries.
Note:	<ol style="list-style-type: none"> <li>1. Remove and insert the battery; the device memorizes previous on/off state by default.</li> <li>2. On/off interval is suggested to be about 10 seconds to avoid the interference of capacitor inductance and other energy storage components.</li> <li>3. Press any function key and insert batteries at the same time; it will enter engineer testing mode.</li> </ol>

### Network Joining

Never joined the network	<p>Turn on the device to search the network.</p> <p>The green indicator stays on for 5 seconds: success</p> <p>The green indicator remains off: fail</p>
Had joined the network	<p>Turn on the device to search the previous network.</p> <p>The green indicator stays on for 5 seconds: success</p> <p>The green indicator remains off: fail</p>

### Function Key

Press and hold for 5 seconds	<p>Restore to factory setting / Turn off</p> <p>The green indicator flashes for 20 times: success</p> <p>The green indicator remains off: fail</p>
Press once	<p>The device is in the network: green indicator flashes once and sends a report</p> <p>The device is not in the network: green indicator remains off</p>

### Sleeping Mode

The device is on and in the network	<p>Sleeping period: Min Interval.</p> <p>When the reportchange exceeds setting value or the state changes: send a data report according to Min Interval.</p>
-------------------------------------	--

### Low Voltage Warning

Low Voltage	2.4V
-------------	------

## 5. Data Report

The device will immediately send a version packet report along with an uplink packet including reed switch status and battery voltage.

Data will be reported by default setting before any configuration.

### Default setting:

Maximum time: 3600s

Minimum time: 3600s (Detect the current voltage value every 3600s by default setting)

Battery change : 0x01 (0.1V)

### R311A status:

When the R311A status changes, it will send a warning report.

Window/Door sensor open : 1

Window/Door sensor close : 0

Please refer Netvox LoRaWAN Application Command document and Netvox Lora Command Resolver

<http://cmddoc.netvoxcloud.com/cmddoc> to resolve uplink data.

### 5.1 Example of ReportDataCmd

FPort: 0x06

Bytes	1	1	1	Var(Fix=8 Bytes)
	Version	DeviceType	ReportType	NetvoxPayloadData

**Version**– 1 byte –0x01—the Version of NetvoxLoRaWAN Application Command Version

**DeviceType**– 1 byte – Device Type of Device

The devicetype is listed in Netvox LoRaWAN Application Devicetype doc

**ReportType** – 1 byte –the presentation of the NetvoxPayloadData, according the devicetype

**NetvoxPayloadData**– Fixed bytes (Fixed =8bytes)

Device	DeviceType	ReportType	NetvoxPayloadData		
R311A	0x02	0x01	Battery (1Byte, unit:0.1V)	ContactSwitchOnOff (1Byte 0:off 1:on)	Reserved (6Bytes, fixed 0x00)

Uplink: 0102011C01000000000000

1<sup>st</sup> byte (01): Version

2<sup>nd</sup> byte (02): DeviceType 0x02 — R311A

3<sup>rd</sup> byte (01): ReportType

4<sup>th</sup> byte (1C): Battery—2.8v , 1C H<sub>ex</sub>=28 D<sub>ec</sub> 28\*0.1v=2.8v

5<sup>th</sup> byte (01): Contact Switch On

6<sup>th</sup> ~ 11<sup>th</sup> byte (000000000000): Reserved

## 5.2 Example of ConfigureCmd

FPort: 0x07

Bytes	1	1	Var (Fix =9 Bytes)
	CmdID	DeviceType	NetvoxPayloadData

**CmdID**— 1 byte

**DeviceType**— 1 byte – Device Type of Device

**NetvoxPayloadData**— var bytes (Max=9bytes)

Description	Device	Cmd ID	Device Type	NetvoxPayloadData			
Config ReportReq	R311A	0x01	0x02	MinTime (2bytes Unit:s)	MaxTime (2bytes Unit:s)	BatteryChange (1byte Unit:0.1v)	Reserved (4Bytes,Fixed 0x00)
Config ReportRsp		0x81		Status (0x00_success)	Reserved (8Bytes,Fixed 0x00)		
ReadConfig ReportReq		0x02		Reserved (9Bytes, Fixed 0x00)			
ReadConfig ReportRsp		0x82		MinTime (2bytes Unit: s)	MaxTime (2bytes Unit: s)	BatteryChange (1byte Unit:0.1v)	Reserved (4Bytes,Fixed 0x00)

### (1) Command Configuration:

MinTime = 1min 、MaxTime = 1min 、BatteryChange = 0.1v

Downlink: 0102003C003C0100000000 003C(H<sub>ex</sub>) = 60(D<sub>ec</sub>)

Response:

810200000000000000000000 ( Configuration success )

810201000000000000000000 ( Configuration failure )

### (2) Read Configuration:

Downlink: 0202000000000000000000

Response:

8202003C003C0100000000 (Current configuration)

### 5.3 Example for MinTime/MaxTime logic

**Example#1** based on MinTime = 1 Hour, MaxTime= 1 Hour, Reportable Change i.e. BatteryVoltageChange=0.1V

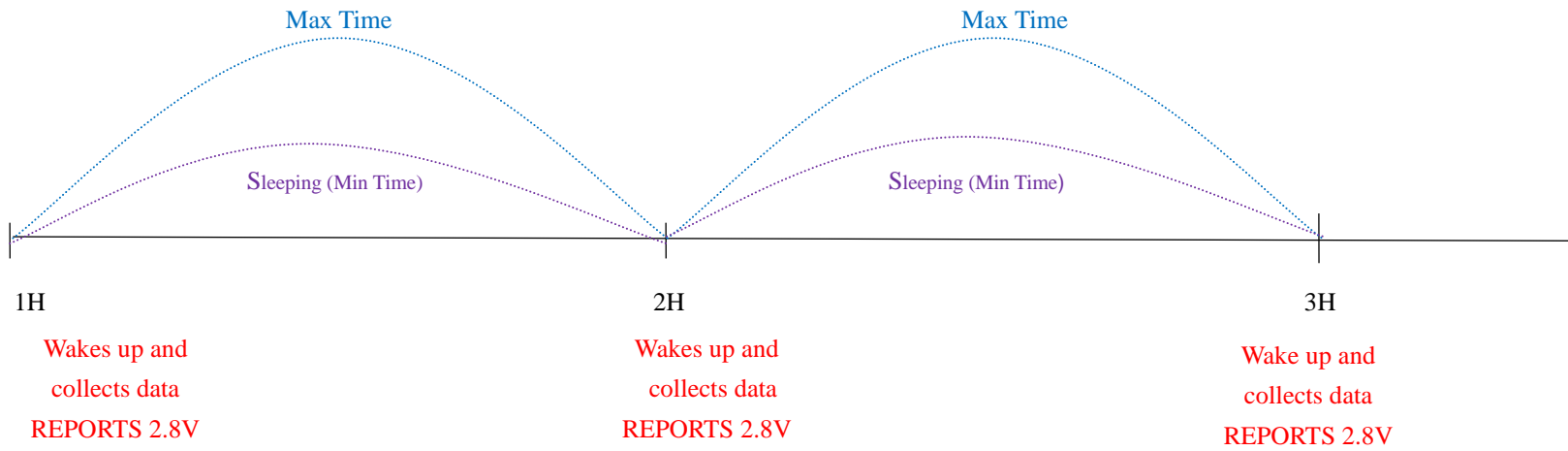

Note:  
MaxTime=MinTime. Data will only be report according to MaxTime (MinTime) duration regardless BatteryVoltageChange value.

**Example#2** based on MinTime = 15 Minutes, MaxTime= 1 Hour, Reportable Change i.e. BatteryVoltageChange= 0.1V.

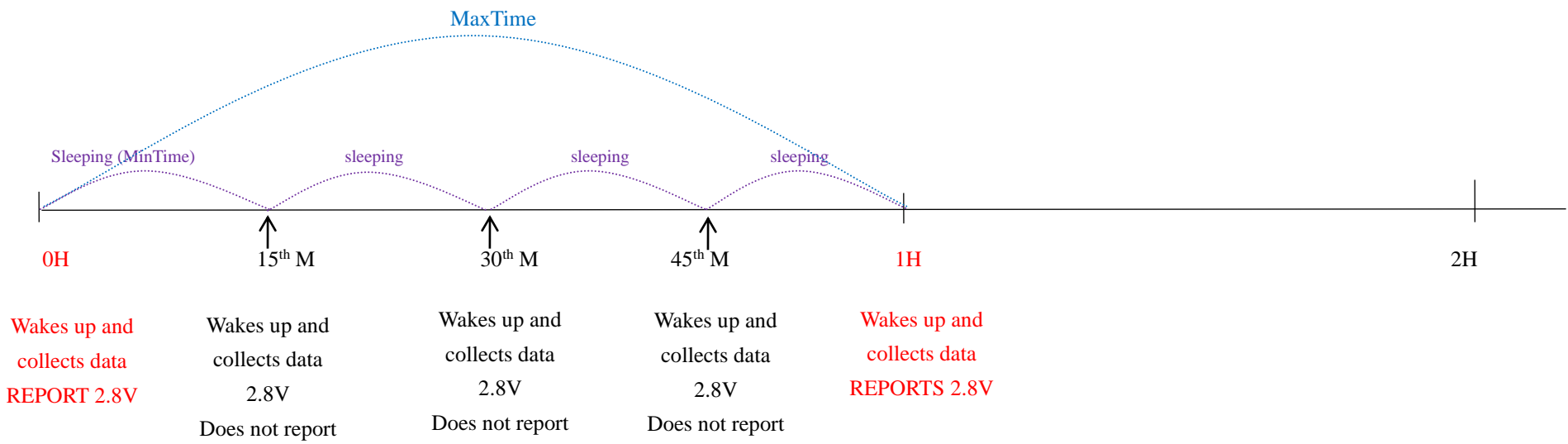

**Example#3** based on MinTime = 15 Minutes, MaxTime= 1 Hour, Reportable Change i.e. BatteryVoltageChange= 0.1V.

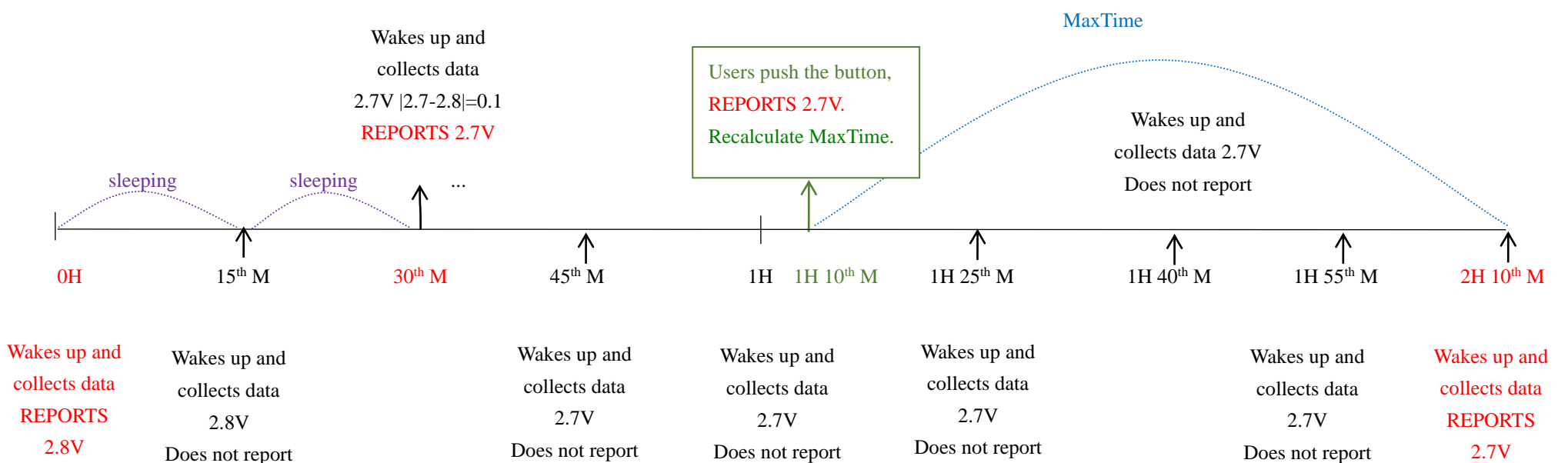



Note:

- 1) The device only wakes up and performs data sampling according to MinTime Interval. When it is sleeping, it does not collect data.
- 2) The data collected is compared with the last data reported. If the data change value is greater than the ReportableChange value, the device reports according to MinTime interval. If the data variation is not greater than the last data reported, the device reports according to MaxTime interval.
- 3) We do not recommend to set the MinTime Interval value too low. If the MinTime Interval is too low, the device wakes up frequently and the battery will be drained soon.
- 4) Whenever the device sends a report, no matter resulting from data variation, button pushed or MaxTime interval, another cycle of MinTime / MaxTime calculation is started.

## 6. Installation

- (1) This product does not have a waterproof function. After the screening is completed, please place it indoors.
- (2) The door magnetic magnet part and the body part are installed on both sides of the door joint or the window joint, and the distance between the two needs to be less than 2cm; the dust in the installation position of the equipment needs to be wiped clean and then affixed to the equipment.
- (3) The battery installation method is shown in the figure below (battery with "+" facing outward).

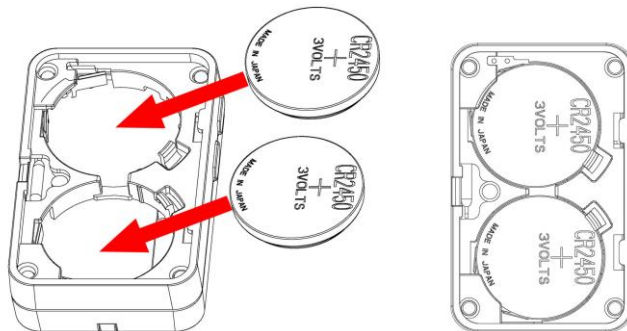

- (4) When installing the device, the magnet **must** move along the X axis relative to the sensor.

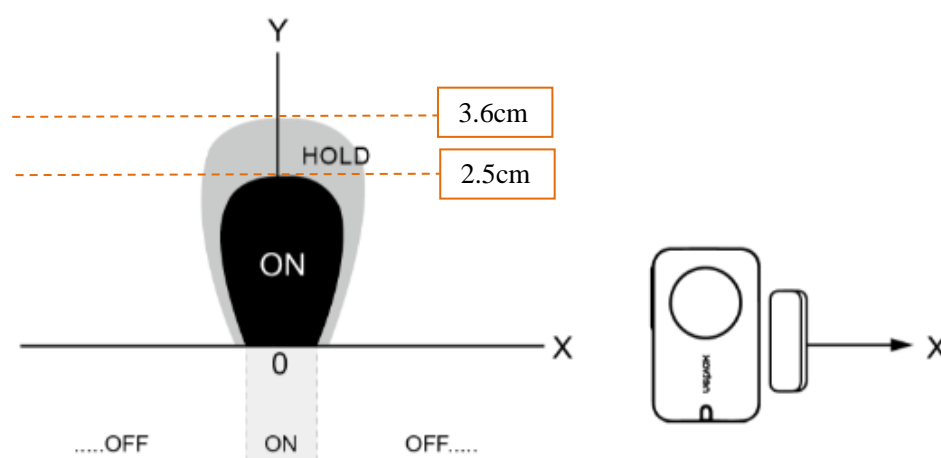

If the magnet moves along the Y axis relative to the sensor, it will cause repeated reports due to the magnetic field.

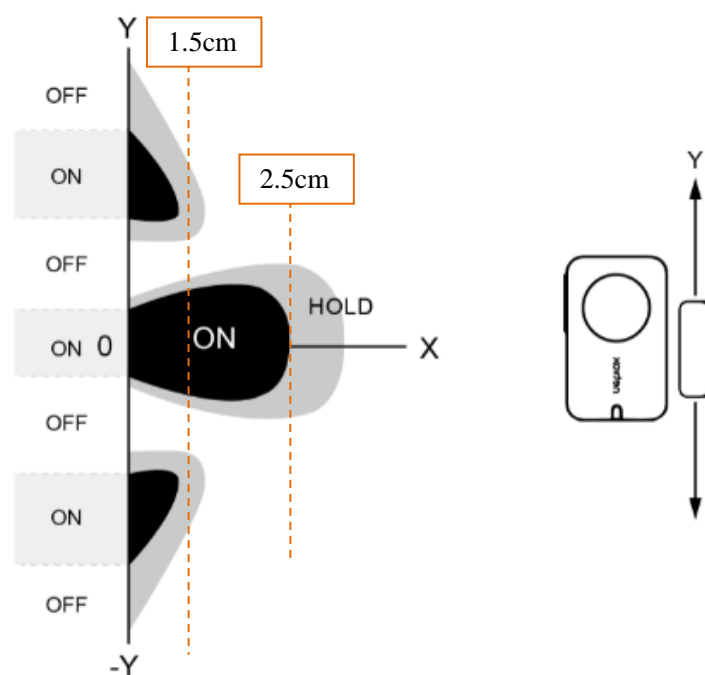

1. Tear off 3M release paper of the magnet body and attach the body to the door frame and stick it to the door in parallel with the door magnet body. (please do not stick it on the rough door to avoid falling off after using the device for a long time).

As shown in the enlarged view on the right



Note:

- Wipe the door clean before installation to avoid dust on the door and affect the adhesion of the device.
- Do not install the device in a metal shielded box or other electrical equipment around it to avoid affecting the wireless transmission of the device.
- The installation distance between the magnet body and the magnet should be less than 2cm.

2. When the door is opened, the magnetic body of the door is separated from the magnet, and the magnetic device sends an "alarm" message.

When the door is closed, the magnetic body of the door is merged with the magnet, the device returns to the "normal" state, and the status information of the off is sent.

This figure shows the scene where the door magnetic sensor (R311A) is applied to the door (opening and closing).

It can also be applied to the following scenarios:

- Door, window
- drawer
- Machine room door
- Archive room
- Closet
- Refrigerator and freezer
- Cargo ship door
- Garage Door



Places which are necessary to detect the opening and closing state

## 7. Important Maintenance Instruction

Kindly pay attention to the following in order to achieve the best maintenance of the product:

- Keep the device dry. Rain, moisture, or any liquid might contain minerals and thus corrode electronic circuits. If the device gets wet, please dry it completely.
- Do not use or store the device in dusty or dirty environment. It might damage its detachable parts and electronic components.
- Do not store the device under excessive heat condition. High temperature can shorten the life of electronic devices, destroy batteries, and deform or melt some plastic parts.
- Do not store the device in places that are too cold. Otherwise, when the temperature rises to normal temperature, moisture will form inside, which will destroy the board.
- Do not throw, knock or shake the device. Rough handling of equipment can destroy internal circuit boards and delicate structures.
- Do not clean the device with strong chemicals, detergents or strong detergents.
- Do not apply the device with paint. Smudges might block in the device and affect the operation.
- Do not throw the battery into the fire, or the battery will explode. Damaged batteries may also explode.

All of the above applies to your device, battery and accessories. If any device is not working properly, please take it to the nearest authorized service facility for repair.