Wireless Dry Contact Interface

Wireless Dry Contact Interface R718J Data Sheet

Wireless Sensor Network Based on LoRa Technology



R718J

Copyright©Netvox Technology Co., Ltd.

This document contains proprietary technical information which is the property of NETVOX Technology. It shall be maintained in strict confidence and shall not be disclosed to other parties, in whole or in part, without written permission of NETVOX Technology.

The specifications are subject to change without prior notice.

Wireless Dry Contact Interface

General Description

Netvox wireless dry contact sensors can be used to detect contact between two wired contact points. This sensor can be used with an external mechanical switch or a contact plate to alert the user via APP when the contacts touch or a switch is triggered.

Principle of Operation

The device can be connected to dry contact devices, such as various switches, buttons, and output of the reed switch. It can detect the closing or disconnecting signal of the dry contact. It uses the SX1276 wireless communication module.

Example Applications

- Tamper Switches
- Barn door access monitoring
- Freezer / cooler door access
- Freezer / cooler doors (to determine if they are not closed all the way)
- Convenience store cooler doors (to determine if they are not closed all the way)
- Forklift seat switches
- Dry contact sensor

Features of NETVOX Sensors

- LoRaWAN™ Class A compatible
- Frequency Hopping Spread Spectrum (FHSS)
- Improved interference immunity
- Improved power management for longer battery life
- Encrypt-RF™ Security (Diffie-Hellman Key Exchange + AES-128 CBC for sensor data messages)
- Battery Life*2:

Please refer to web: http://www.netvox.com.tw/electric/electric_calc.html

At this website, users can find battery life time for various models at different configurations.

- Over-the-air updates (future)
- Third-Party online wireless sensor monitoring and notification system to configure sensors, view data and set alerts via SMS text and email (optional)
- Available third-party platform: Actility/ThingPark, TTN, MyDevices/Cayenne
- R718X series carry magnets which can be attached to ferromagnetic materials and objects

*1. Actual range may vary depending on environment.

*2. Battery life is determined by sensor reporting frequency and other variables

Wireless Dry Contact Interface

Technical Specifications (Main Part)

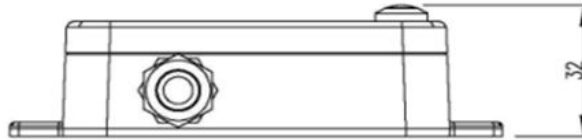
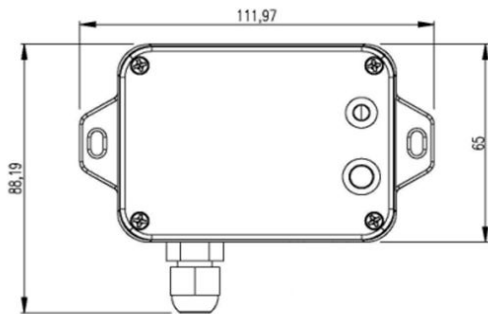

(Uni. mm)

Electric

Input Power	2 x 3.6V ER14505 AA lithium batteries (3.6V2400mah/section)
Sleeping Mode	22uA
Wake up Mode	6.3mA@3.3V
Receiving Current (max)	11mA @3.3V
Transmitting Current (max)	120mA/3.3V
Battery Voltage Measurement Accuracy	±0.1V
Low Voltage Threshold	3.2V

* Specific electrical characteristics may vary depending on the power supply voltage.

External Wire Specification

Wire material	UL2547 28AWG
Wire maximum temperature	80° C
Maximum outer diameter of the wire	2mm
Wire length	1000mm (±5mm)
Wire flame resistance rating	VW-1

Wireless Dry Contact Interface

Frequency

TX Power	19dBm±1dBm
Rx Sensitivity	-136dBm (LoRa, Spreading Factor=12, Bit Rate=293bps) -121dBm (FSK,Frequency deviation=5kHz, Bit Rate=1.2kbps)
Antenna Type	Build-in antenna
Communication Range	Up to10 km, the actual transmission distance depends on the environment.
Data Transfer Rate	0.3kbps~50kbps
Spread Technique	LoRa/FSK
Available Frequency	EU863-870, US902-928, AU915-928, KR920-923, AS923, CN470-510 (Configured before shipment)

Physical

Dimension	Main Part: L: 112mm*W: 65mm*H: 32mm
Weight	141g
Environment Temperature Range	-20℃ ~ 55℃
Environment Humidity Range	<90% RH (No condensation)
Storage Temperature	-40℃ ~ 85℃

Contact:**NETVOX TECHNOLOGY CO., LTD.****TEL: 886-6-2617641****FAX: 886-6-2656120****E-mail: sales@netvox.com.tw****WEB: www.netvox.com.tw****NETVOX TECHNOLOGY CO., LTD (XIAMEN)****TEL: 86-592-5717188****FAX: 86-592-5717180****E-mail: dyx@netvox.com.cn****WEB: www.netvox.com.cn**